

DESCRIPTION

BACHFIRE Z E120 is an Automatic Fire Curtain that in the case of fire, limits and controls the fire, with classification E120. This system can be adapted to irregular geometric perimeters open or close ones in order to avoid vertical beams.

The curtain is composed by: fiberglass fabric with polyurethane coating on both sides seamed with reinforced steel wire and fixed to a 2mm plate inside head-box and to the bottom bar; galvanized steel elements as head-box, side guides and bottom bar.

All the system is driven by at least with one 230V tubular motor with special gravity fail safe system.

The control panel for automatic curtains (CBM), has nominal input voltage of 115Vac/ 220Vac and output voltage of 230V/24V.

Uninterruptible Power Supply (UPS System) with autonomy up to 6 hours exists in all control panels.

Tested and approved according to the European Standards UNE EN 1634-1 and UNE EN 1363-1.



bachfire z

OPERATION

The system can be activated by a SHEV, fire alarm contact, internal fire and smoke detection devices, or manual emergency buttons. In the event of a fire, the BACH's Control Panel (CBM), receives the signal alarm, and the automatic curtain deploys automatically, with controlled and safe constant speed of descent even following total power loss on all curtains. If there is a false alarm the curtains return to stand-by position automatically after reset of alarm from main Fire Management Systems. In case of main power loss, the curtain will remain fully retracted thanks to BACH's battery back-up system.

FABRIC

The fiberglass fabric resists up to 1100°C sewed as a concertina shape. The polyurethane coating on both sides guarantees mechanical stability when handling the fabric not only in the sewing process but also during the installation. All seams are done with reinforced stainless steel wires with a coating of Kevlar.

HEADBOX

Galvanized Steel head-box 1,2mm thickness with different possibilities to adapt to different architectural spaces, and maintenance requirements. Dimensions of the head-box varies depending on width and height of the curtain.

SIDE GUIDES

Galvanized Steel from 1,5 to 3mm thickness and different dimensions depending on width and height of the curtain.

ROLLER

Galvanized Steel of 3mm thickness and 42mm diameter with chain connected to an external motor.

BOTTOM BAR

Galvanized Steel of 1,5mm thickness.

ELECTRIC MOTOR

Motor 230V/ brake 24V

Maximum power: 120 Nm/ 240W

Maximum current: 6A

Average linear speed: not defined (depends on the dimension of the curtain)

CBM CONTROL PANEL

Receives the signal alarm from Fire Management System and controls the movement of curtains. Visual and acoustic alert system.

Dimensions (W x H x D): 400 x 500 x 200mm

Input: 115 or 220 Vac 50Hz

Output: 24Vcc/ 230V

Battery: 2 x 12Vcc 7,5 Ah rechargeable (up to 6 hours autonomy)

OPTIONAL EXTRAS

RAL coating: head-box, side guides, bottom bar.

Stainless steel elements: head-box, side guides, bottom bar, screws, rivets.

CBM control panel: special designs with additional information output, micro switches, communication with other devices, special battery backup, possibility of delaying curtain deployment.

Emergency button: pushing this button the curtain deploys immediately.

Note: other requirements and customized solutions on demand.

HEADBOX

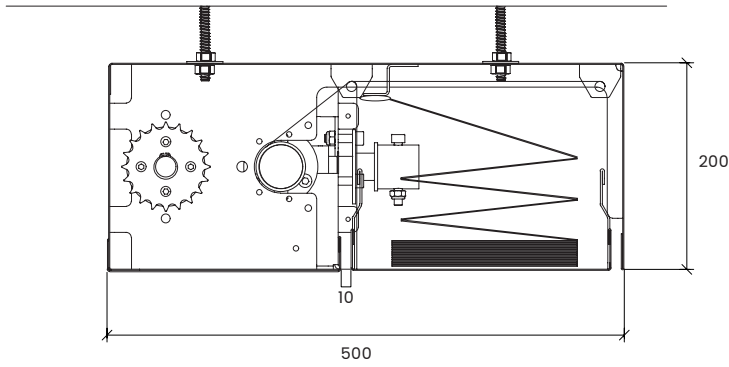

HEADBOX DETAIL FABRIC UP

PLANT PERIMETER TYPES

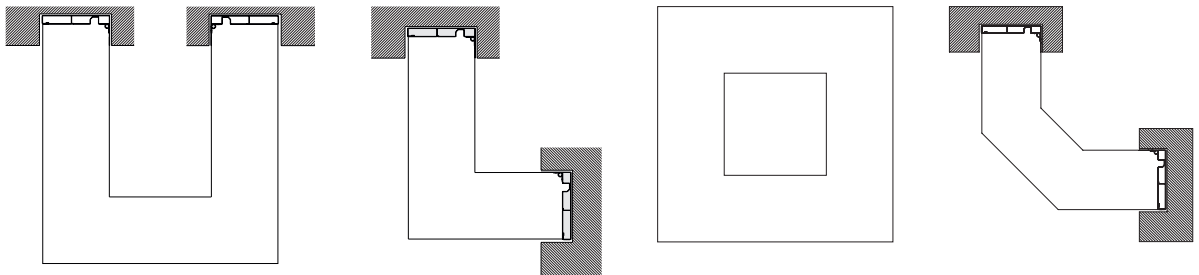

U SHAPE

L SHAPE

O SHAPE

IRREGULAR SHAPE

SIDE GUIDE FIXING

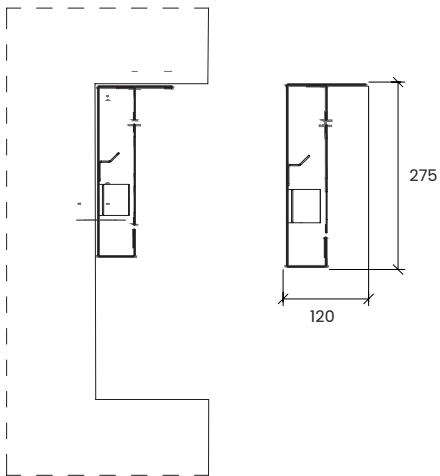

SIDE GUIDE FOR OPEN DIAMETER

BOTTOM BAR

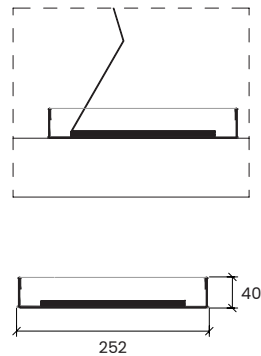

BOTTOM BAR DOWN

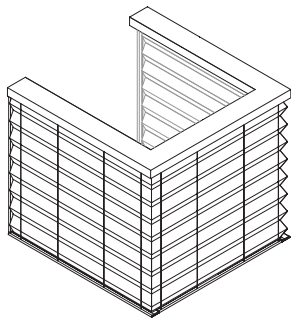

U SHAPE

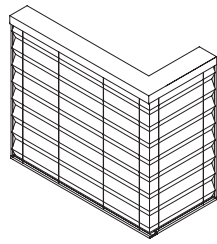

L SHAPE

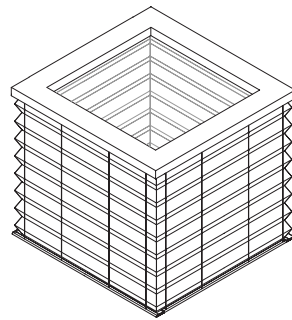

O SHAPE

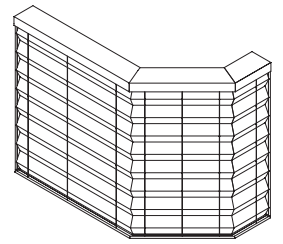

IRREGULAR SHAPE

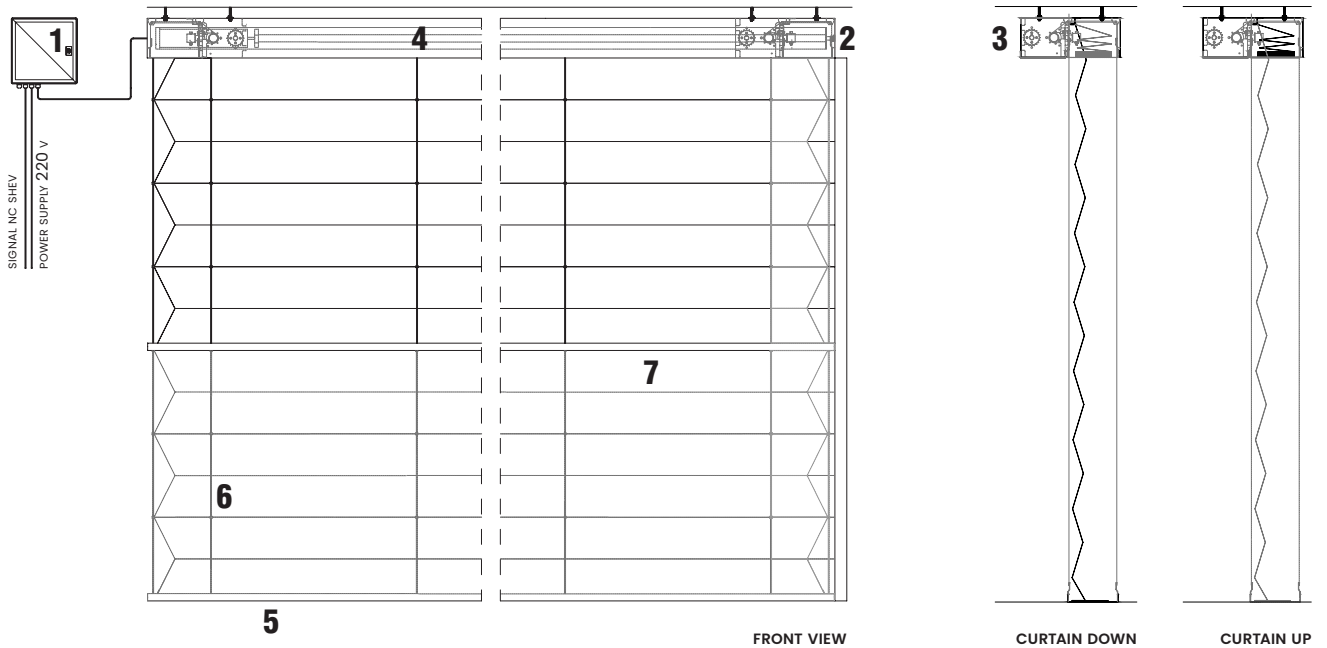

- | | |
|------------------------------|--------------------------------|
| 1. control panel CBM | 5. galvanized steel bottom bar |
| 2. tubular motor 230v | 6. lifting strips |
| 3. galvanized steel head-box | 7. concertina fabric |
| 4. galvanized steel roller | |